

Type: 483



Single pole, miniaturised, aircraft style thermal circuit breaker with tease-free, trip-free, snap action mechanism and push/pull on/off manual actuation (M-type TO CBE to EN 60934). An indicator band on the push button clearly shows the tripped/off position. Threadneck panel mounted, available in metric and US (MS 3320) configurations. Advanced two-chamber design contributes to fail-safe operation. Temperature compensated from -55° to +125 °C, with optional auxiliary contacts, and fully approved for use on a wide range of aircraft and equipment. Full specification ensures suitability for the most demanding applications. For three pole version see type 583.

Voltage rating:

- AC 115 V (400 Hz)
 - DC 28 V
- higher voltage ratings upon request

Current ratings:

from 1 A to 35 A

Number of poles:

single pole

Mounting method:

threadneck

Terminal design:

screw terminals

Actuation:

manual release
push button

Auxiliary contacts:

with auxiliary contacts
without auxiliary contacts

Water splash protection:

with water splash protection
without water splash protection

Illumination:

without illumination

Typical life:

20,000 operations mechanical or
10,000 operations at $1 \times I_N$ (≤ 25 A)
5,000 operations at $1 \times I_N$ (30 + 35 A)

Interrupting capacity I_{cn} :

AC 115 V (400 Hz):
 ≤ 4 A: 1,000 A
 5 A: 2,000 A
 7,5...35 A: 2 500 A
 DC 28V:
 1...25 A: 6,000 A
 30 + 35 A: 4,000 A

Approvals:

LN 29886, UL, VG 95345 part T06, MS 3320, QPL

Dimensions

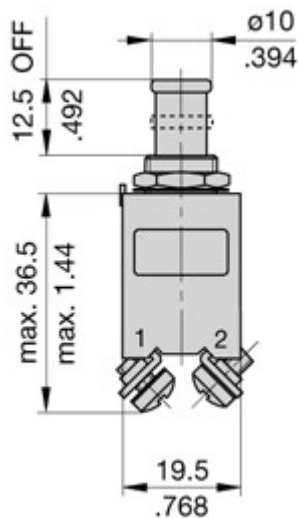

Internal connection diagrams

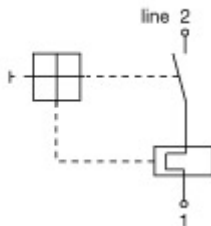

Description

Single pole, miniaturised, aircraft style thermal circuit breaker with tease-free, trip-free, snap action mechanism and push/pull on/off manual actuation (M-type TO CBE to EN 60934). An indicator band on the push button clearly shows the tripped/off position. Threadneck panel mounted, available in metric and US (MS 3320) configurations. Advanced two-chamber design contributes to fail-safe operation. Temperature compensated from -55° to +125 °C, with optional auxiliary contacts, and fully approved for use on a wide range of aircraft and equipment. Full specification ensures suitability for the most demanding applications. For three pole version see type 583.

Typical applications

Aircraft systems and equipment (fixed wing and helicopters); other extra low voltage wiring applications; defence equipment; communications systems.

Standard current ratings and typical volt drop values

Current rating (A)	Volt drop (mV)	Current rating (A)	Volt drop (mV)
1	750	10	190
2	520	15	190
2.5	400	20	200
3	360	25	170
4	350	30	160
5	260	35	150
7.5	230		

Approvals

Authority	Voltage ratings	Current ratings
LN 29886		
VG 95345 T06		
MS 3320, MS 3320 V		
QPL		
UL	AC 250 V, 50/60 Hz DC 75 V	1...25 A 1...35 A



Technical data

Voltage rating	AC 115 V (400 Hz); DC 28 V (higher voltage ratings upon request)	
Current rating range	1...35 A	
Auxiliary circuit	0.5 A, DC 28 V	
Typical life	20,000 operations mechanical or 10,000 operations at I_N (≤ 25 A) 5,000 operations at I_N (30 + 35 A)	
Ambient temperature	-55...+125 °C (-67...+257 °F)	
Insulation co-ordination (IEC 60664 and 60664A)	rated impulse withstand voltage 1.5 kV	pollution degree 3
Dielectric strength (IEC 60664 and 60664A)	test voltage operating area main to aux. circuit	AC 1,500 V AC 1,500 V
Insulation resistance	> 100 M Ω (DC 500 V)	
Interrupting capacity I_{cn}	AC 115 V (400 Hz): ≤ 4 A 1,000 A 5 A 2,000 A 7.5...35 A 2,500 A DC 28 V: 1...25 A 6,000 A 30 + 35 A 4,000 A	
Degree of protection (IEC 60529/DIN 40050)	operating area IP40 terminal area IP00	
Vibration (sinusoidal)	15 g (70-2000 Hz), ± 0.76 mm (5-70 Hz) to VG 95210, sheet 19, IEC 60068-2-6, test Fc/ISO 7137	
Vibration (random)	16.4 g rms, 0.2 g ² /Hz ± 1.5 dB to VG 95210, sheet 29, ISO 7137	
Acceleration	17 g, to ISO 2669	
Shock	75 g (11 ms) to VG 95210, sheet 28, IEC 60068-2-27, test Ea/ISO 7137	
Corrosion	96 hours at 5 % salt mist, severity A 48 hours at 20 % salt mist, severity B to VG 95210, sheet 2, IEC 60068-2-11, test Ka/ISO 7137	
Humidity	240 hours at 95 % RH, to VG 95210, sheet 7, IEC 60068-2-3, test C/ISO 7137	
Explosion	to VG 95210, sheet 10, MIL-STD-202, meth. 109	
Altitude	$\leq 25,000$ m above sea level	
Mass	max. 29 g with auxiliary contact max. 25 g without auxiliary contact	

Weight reduction through aluminium threadneck: approx. 3 g

All dimensions without tolerances are for reference only. In the interest of improved design, performance and cost effectiveness the right to make changes in these specifications without notice is reserved. Product markings may not be exactly as the ordering codes. Errors and omissions excepted.

Ordering information

Type No.	
483	single pole, with temperature compensation
Mounting	
G	threadneck panel mounting, standard
L	threadneck panel mounting, extended push button
V	threadneck panel mounting, high vibration performance
Threadneck design	
1	M12x1x6.4x8.8 dia. with mounting plate (aux. contact version)
2	15/32-32UNx6.4x7.8 dia. (without aux. contact)
3	MJ12x6.4x8.8 dia. (without aux. contact)
4	M12x1x6.4x8.8 dia. (without aux. contact)
5	7/16-32UNx6.4x7.8 dia. (without aux. contact)
6	M12x1x9.4x8.8 dia. (without aux. contact)
7	7/16-32 UNx6.4x7.8 dia. with mounting plate (aux. contact version)
8	as 483-G1...but with aluminium threadneck (only mounting -G and aux. contact versions S1, S5)
Hardware for threadneck (washers)	
0	without hardware
1	wave washer 12/15 - mounted
2	mounted washer 12.1/17.2 - mounted
3	mounted washer 11.3/14.9 - mounted (threadneck design 5,7 only)
4	mounted washer 12/15 - mounted
5	tooth washer 12.1/17.2, bulk shipped
Hardware for threadneck (nuts)	
0	without hardware
1	hex nut M12x1 (threadneck design 1, 4, 6 only)
2	hex nut 15/32-32UN (threadneck design 2 only)
3	hex nut 7/16-32UN (threadneck design 5, 7 only)
4	hex nut M12x1, aluminium, fitted (threadneck design 8 only)
5	hex nut MJ12x1 (only with threadneck design 3)
6	hex nut M12x1, bulk shipped (threadneck design 1,4,6)
Terminal design (main terminals)	
K screws terminals with metric thread	
1	K14 (M4, MJ4)
J screw terminals with inch thread	
1	J14 (8-32UNC-2B)
2	J17 (8-32UNC-2B)
3	J25 (6-32UNC-2B)
Characteristic curve	
M1	thermal, 1.15-1.38 I _N
Terminal screws	
A	Phillips screw M4x6
B	Phillips screw 8-32UNC-2Ax6 (MS 51957-41)
C	Phillips screw 6-32UNC-2Ax6 (MS 51957-26)
D	slotted flat head screw M4x6
E	hex screw with Phillips head 8-32UNC-3A-9.5
K	hex screw with Phillips head 8-32UNC-3Ax7.6
L	Phillips screw MJ4x6
M	as "K" but bulk shipped
Z	without accessories
Terminal washers	
0	without lock washer
1	lock washer B4
2	lock washer 4.3 (MS 35338-137)
3	lock washer B4 and washer 4.4/9.5
4	lock washer 3.7 (MS 35338-136)
5	lock washer 4.3/9
Auxiliary contact	
S0	without auxiliary contact
S1	with auxiliary contact (N/C) connector to EN3155-016M2018, size 20
S5	with polarized auxiliary contact (N/C)
Barrier	
Z	without barrier (standard)
Colour of the push button	
blank: black (standard) (e. g. 7.5)	
A	green (e. g. 7.5)
G	green, marking to EN (e. g. 7 1/2)
N	black, marking to EN (e. g. 7 1/2)
Current ratings	
1...35 A	
483 - G 4 1 1 - K 1 M1 - A 1 S0 Z . - 5 A ordering example	

Ordering information for approved devices

483-G411-K1M1-A1S0ZN

Metric threadneck M12x1 and terminal design -K14 (M4x6), listed by the German Materialamt der Bundeswehr to VG 95345 T06.

483-G111-K1M1-A1S1ZN

Metric threadneck M12x1 and terminal design -K14 (M4x6) and auxiliary contact -Si, listed by the German Materialamt der Bundeswehr to VG 95345 T06.

483-G533-J1M1-B2S0ZN (MS 3320)

Threadneck size 7/16-32UNSx6.4 and terminal design -J14 (inch thread 8-32), approved to MS 3320.

483-V533-J1M1-B2S0ZN (MS 3320-V)

Threadneck size 7/16-32UNSx6.4 and terminal design -J14 (inch thread 8-32), approved to MS 3320-V.

483-G533-J3M1-C4S0Z

Threadneck size 7/16-32UNSx6.4 and terminal design -J25 (inch thread 6-32), listed by the German Materialamt der Bundeswehr to VG 95345, part 6.

483-G814-K1M1-A1S1ZN

Aluminium threadneck M12x1x6.4x8.8 dia.

Internal connection diagrams

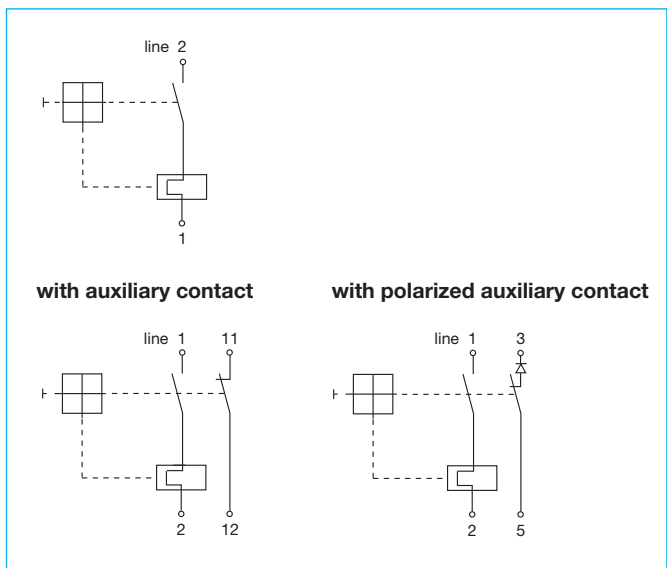

Dimensions 483-G411-K1M1-A1S0ZN (VG 95345 T06)

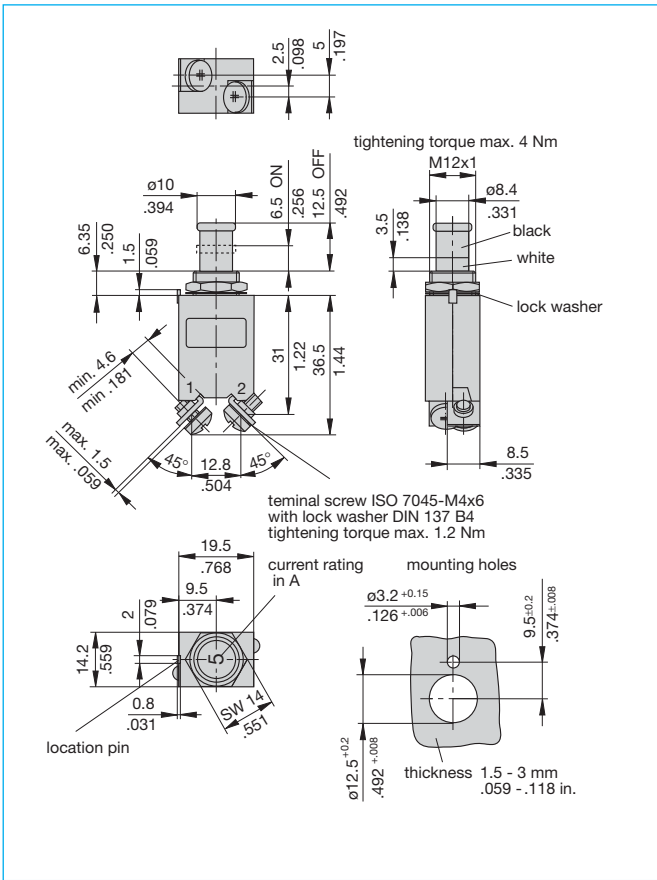

Dimensions 483-G111-K1M1-A1S1ZN (VG 95345 T06)

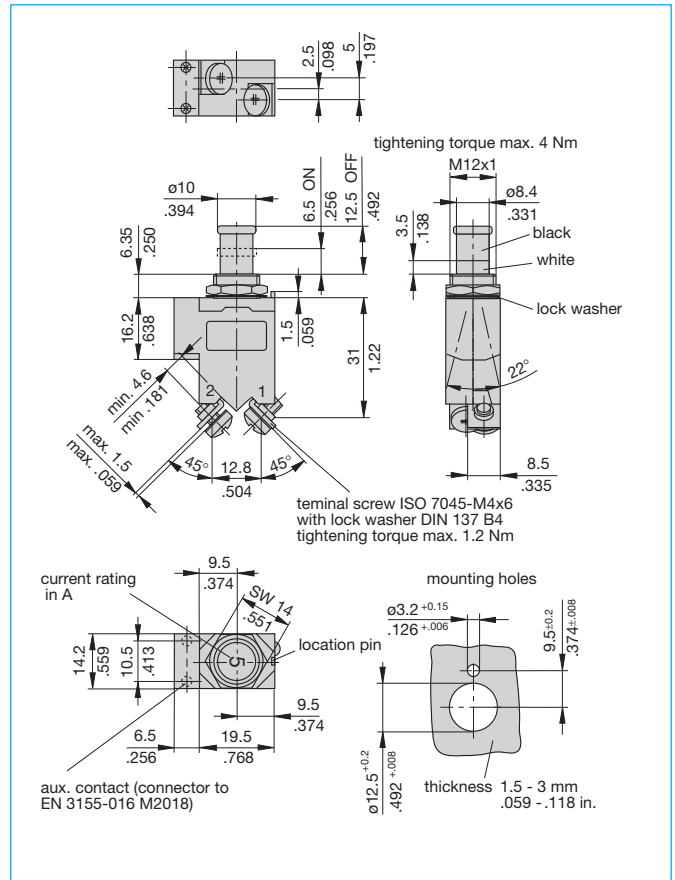

Dimensions 483-G533-J1M1-B2S0ZN (MS 3320)

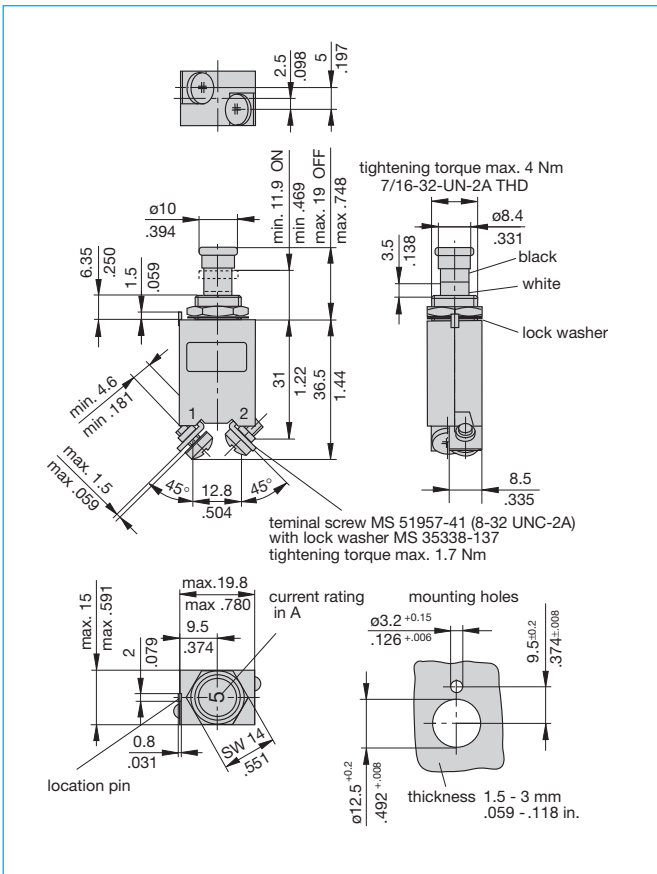

Mounting

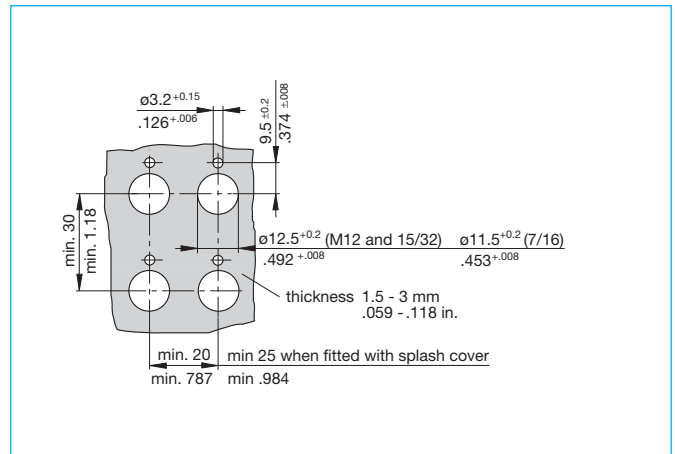

This is a metric design and millimeter dimensions take precedence (mm)
inch